



**SkyHawk M1620 Satellite Modem  
Installation and Setup Guide**

**READ ME FIRST**



## Location, Location, Location

Installing a SkyHawk M1620 Satellite Modem is not the same as installing a satellite dish for television. It is important that you install the SkyHawk in a good location for best performance. But just what is a good location? Read on. We'll try to explain.

The SkyHawk needs to have a direct line of sight to the Globalstar satellites. That means it needs to be able to see the sky with nothing in the way. You may be familiar with television satellites that are in a fixed location in the sky. For those satellites, you can aim an antenna at one place, and it doesn't matter whether you have a clear view of any other part of the sky.

Globalstar is different. Globalstar satellites move. They come up over the horizon, zip across the sky, and then drop behind a hill. They follow different paths.

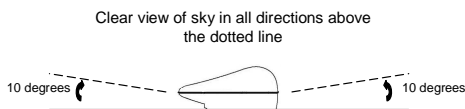

**The SkyHawk must have a clear view of the entire sky or it will not perform well. The SkyHawk should have an unobstructed view of the sky down to 10 degrees above the horizon.**

Because you don't know what part of the sky the satellites will be in, you need to find a location where the SkyHawk can see as much of the sky as possible. The rule is that the SkyHawk should see the entire sky down to 10 degrees above the horizon.

The modem and satellites use a different kind of radio signal: high frequency microwave signals. Unlike television and AM or FM radio signals, or even cellular phone signals, microwave radio signals do not bend. They are strictly line of sight. This means that these signals do not go through walls. They do not go around hills or through trees or over bushes. If something gets between the satellite and the SkyHawk, the SkyHawk won't work.

Sometimes it won't be possible to get such a full clear view. In that case, you should try to find a location that gets as full and clear a view of the sky as possible.

### ***Fine points of antenna location***

As we said before, the Globalstar satellites are always moving. They zip across the sky, taking from 10 to 15 minutes to go from horizon to horizon.

Sometimes a person will install a SkyHawk in a bad location, and be fooled into thinking the installation is correct just because they were able to make a call. Don't be fooled! Just because you can make a call now doesn't mean you will be able to make a call a few minutes later when the satellites have changed position. The only way to ensure that the SkyHawk will work reliably and consistently is to make sure the SkyHawk can see most of the sky. You can't tell a good location from a bad location by making a test call.

## Types of Obstructions

Sometimes it is very difficult to find a location where there is nothing at all between the antenna and some part of the sky. Some obvious challenges are trees, power lines, television antennas, and lightning rods. The ideal location has nothing in the way. However, some things can sit in the path between the SkyHawk and the satellite without causing harm.

### ***Buildings***

Generally, you can not mount the SkyHawk beside a building or tall wall. Mounted beside a building, the SkyHawk would only see half the sky. However, you could mount a mast bracket on the side of a building, then extend the mast up above the roof, and mount the SkyHawk there.

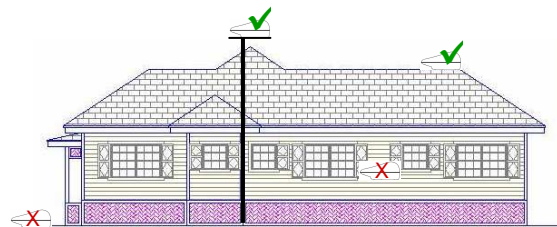

### ***Power lines***

Power lines are usually not a problem. As long as the SkyHawk is at least 10 feet away from the power lines, the signal will be able to go through the power lines without a problem. Power poles can block the signal however. Try to avoid having power pole blockage. If it is impossible to avoid power pole blockage, try to locate the SkyHawk as far from the power poles as possible.

### ***Television Antennas / Radio Towers***

Many homes have tall television antennas on their roofs, while businesses may be close to tall metallic towers. It would often be quite difficult to put the SkyHawk high enough to avoid having the antenna or tower in the way. You do not have to put the

SkyHawk higher than the antenna. If you locate the SkyHawk at least 10 feet away from the antenna and mast, the antenna and mast will not cause blockage. (This presumes a standard 1 1/2 inch diameter television antenna mast. If, instead of a simple mast, you have a large antenna tower, then you should try to locate the SkyHawk farther away.)

### Trees

Trees are almost always bad for satellite reception. Try to avoid them.

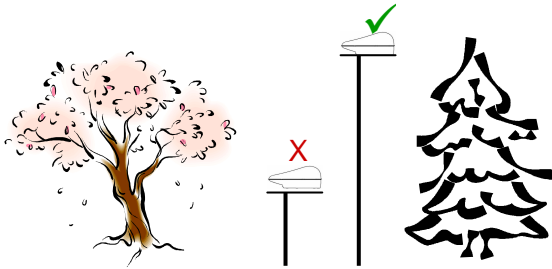

The Globalstar signal will go through some thin trees. However, trees will grow, and the problem will get worse over time. Trees also cause much more blockage when they are wet. The signal may find its way through the trees this afternoon, but have more trouble in the evening after the sun sets and dew forms on the leaves. Try to avoid having trees in the way of your satellite signals.

If your location is surrounded by trees, you should consider putting the SkyHawk on a mast.

Ideally, the mast would be tall enough so that the antenna of the SkyHawk can see most of the sky.

### Chimneys / Engine Exhausts

The Globalstar signal will not go through a chimney. If you mount the antenna beside a chimney, the signal will not be able to go through it, and the antenna will only see part of the sky. If you attach a mast to a chimney mount, then extend the SkyHawk above the chimney, you may have a good installation.

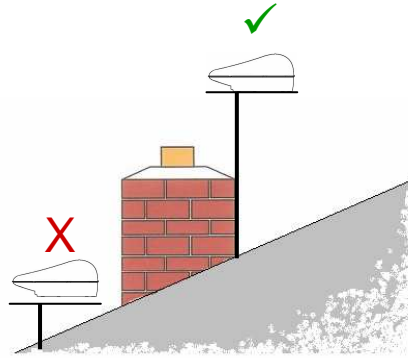

Remember, soot from a chimney or engine exhaust may accumulate on the antenna over time. Soot contains carbon that will block the signal. Soot buildup will cause problems over time. If your fireplace burns anything but gas, avoid putting your SkyHawk in that location. If the chimney is fed only by gas appliances, then installing the SkyHawk there may be acceptable. Extend the mast a few feet above the chimney so that hot gasses from the chimney don't damage the enclosure or cabling. In any case, periodic inspection and cleaning to remove soot is recommended.

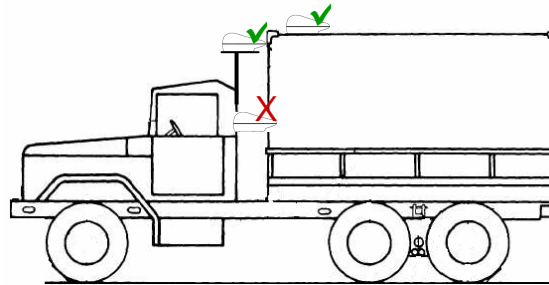





Soot produced by diesel exhausts also contains carbon which will block the signal as it accumulates. Periodic washing will remove soot buildup.

When mounting the SkyHawk to a vehicle, make sure a clear view of the sky is maintained when the trailer is attached. If necessary the SkyHawk can be mounted on a mast attached to the cab, or directly to the trailer.

## Installation

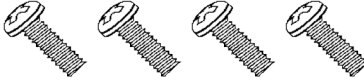
### Step 1: Inventory

Check the contents of your package and ensure you have the following:

Item	Description
	SkyHawk M1620 Modem
	(4) 1/4-28 5/8" stainless steel machine screws
	DC power cable, 25', tinned wire leads on power supply end
	Sealed serial cable, 25'
	Manual and Service Tool CD

### Step 2: Power Supply

The SkyHawk requires a DC power source capable of delivering 10 Watts of power at any voltage between 12 and 33 Volts DC. A power supply is not included in the package. Suitable power sources are a vehicle's battery or ignition system (12 or 24V, 1A fuse minimum) or any 12V AC adapter rated for 1000mA or higher.

### Step 3: Optional Materials

You may require a pole mount or other mounting bracket to properly locate and install your SkyHawk. Because each installation is unique and has different needs, mounting poles and brackets are not provided. See the mounting diagram at the end of this guide for the location of mounting holes.

Mounting the SkyHawk in mobile applications (e.g. on a truck or other vehicle) requires protection against vibration. A vehicle mounting kit is available directly from Blue Oceans. Call 1-888-258-3797 or email [sales@blueoceans.ca](mailto:sales@blueoceans.ca) for more information.

## Step 4: Tools Required

- Drill
- 3/8" Drill Bit
- Phillips Screwdriver
- Flat Head Screwdriver
- Personal Computer with Windows XP, available serial port and CD-ROM drive (optional)

## Step 5: Location

Choose a good location, keeping in mind the requirements for a good location described at the front of this guide.

The SkyHawk must be mounted horizontally as the enclosed antenna is not designed to provide reception below the unit.

The SkyHawk comes with a 25 foot sealed serial cable and a 25 foot power cable. This is sufficient for most installations. If you need longer cables because the SkyHawk needs to be further from your working location, measure the distance from the SkyHawk's planned location to determine the length of cable needed.

The power cable can be extended by using any 18AWG 2 conductor wire (e.g. General Cable / Carol Brand E2033S). Splice or crimp the wire ends together and use a small piece of shrink tubing to seal the cable splice against water damage.

The serial cable can be extended by using any 9 pin straight through serial cable. **Use of a standard serial cable to connect directly to the SkyHawk is not recommended.** The supplied cable uses a special watertight seal to prevent corrosion to the pins on the SkyHawk.

## Step 6: Mounting and Testing

1. Mount the SkyHawk using the 4 supplied machine screws.
2. Connect the power cable to the SkyHawk. When mating the plug and receptacle connector, make sure the alignment dots are aligned prior to mating the connectors. This ensures proper mating without damage to the connectors.

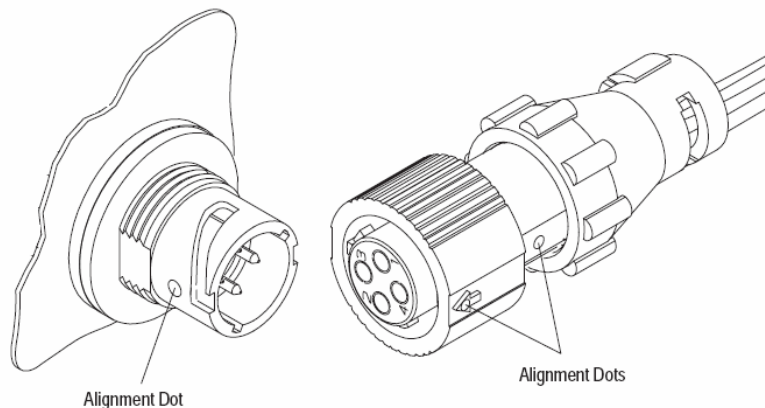

- Press the connector firmly onto the SkyHawk power receptacle with all 3 alignment dots in a row. Then twist clockwise ¼ turn to lock the connector in place.
3. If you do not want to test the SkyHawk, skip to Step 4.
    - a. Remove the watertight protective cover from the AUX port on the SkyHawk. Then connect the serial cable to the AUX port.
    - b. Connect the power cable to your power supply and turn it on.

- c. Connect the serial cable to a serial port on your PC. Insert the CD ROM into your PC's CD ROM drive.
  - d. From the CD ROM, run the service tool (Service Tool.exe). Select your COM port from the drop down list and press OK.
  - e. The Connection Status window will update as the SkyHawk performs a full diagnostics test.
  - f. We highly recommend you use the Service Tool to evaluate the quality of your location. A full description of the Service Tool and how to run a Service Logging session is provided in the SkyHawk User's Manual on the CD.
  - g. When complete, remove the serial cable and replace the watertight protective cover.
4. Connect the serial cable to the MODEM port on the enclosure, and your computer or other equipment.
  5. Connect the power cable to your power supply and turn it on.

The SkyHawk modem is very flexible and supports many different configurations. To quickly get up and running using a PC, insert the Globalstar Express Data CD and follow the instructions. A full description of the SkyHawk's capabilities and how to configure it is provided in the User Manual on the supplied CD ROM.

## Mounting Diagram

